

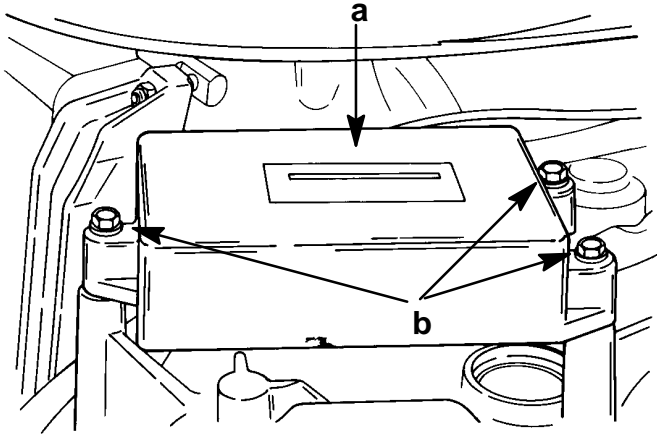

## LOW SPEED/HIGH SPEED SPARK ADVANCE MODULE REMOVAL

1. Disconnect spark advance module harness leads from switch box.
2. Remove 3 bolts securing module to powerhead and remove module.



51843

- a - Low Speed/High Speed Advance Module  
b - Bolts (3)

## LOW SPEED/HIGH SPEED SPARK ADVANCE MODULE INSTALLATION

1. Connect module harness leads to switch box.
2. Apply Loctite 222 (FT2962-2) to threads of 3 module mounting bolts and secure module to powerhead.
3. Torque bolts to 30 lb. in. (3.5 N·m).

## Idle Stabilizer Modules

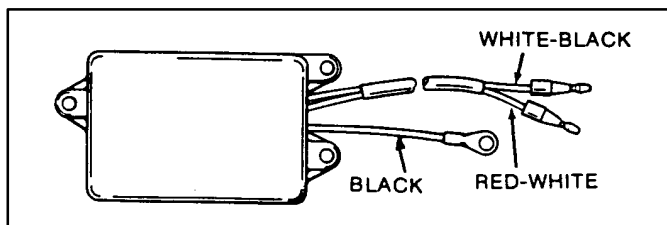

### Idle Stabilizer

#### IDLE STABILIZER DESCRIPTION

The idle stabilizer will electronically advance the ignition timing by as much as 9° if the engine idle speed falls below approximately 550 RPM. This timing advance raises the idle RPM to an acceptable level (550 RPM). When the idle stabilizer senses the idle RPM has reached the acceptable level, it returns the timing to the normal idle timing.

## TEST FOR PROPER FUNCTION OF IDLE STABILIZER

**IMPORTANT:** Due to the sensitivity characteristics of individual modules and tachometer variances, the engine RPM at which the module will advance/retard the ignition timing may vary slightly from specification.

Connect a timing light to No. 1 spark plug lead (top, starboard bank). Start the engine, and allow it to idle above 600 RPM, then retard the ignition timing by slowly pulling forward on the spark advance lever. Observe that the system is functioning by noting a rapid spark advance (as much as 9° from the idle setting) as the engine slows down to below approximately 550 RPM.

The idle stabilizer is not repairable. Should the idle stabilizer fail to function as described, it will require replacement.

## Idle Stabilizer Shift System (XR6 and Magnum III Models)

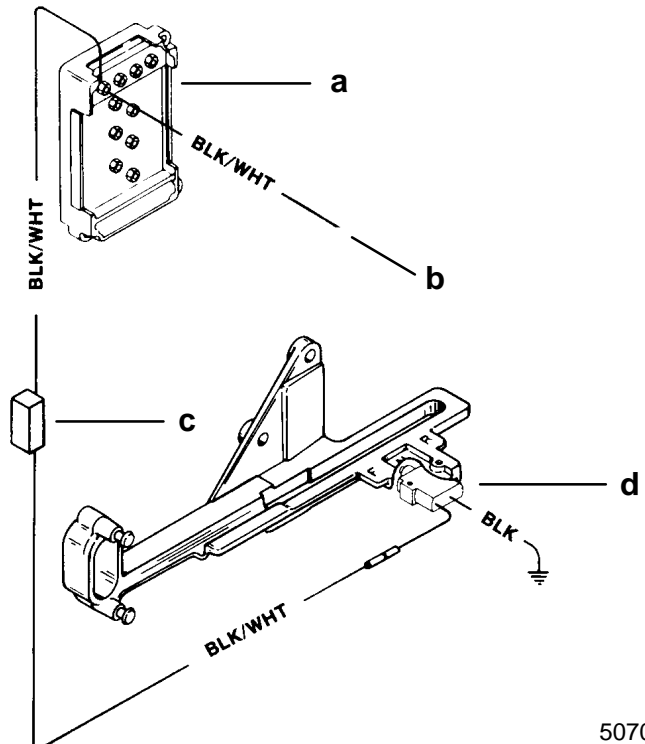

50707

- a - Inner Switch Box  
b - To Outer Switch Box  
c - Resistor (6.8K)  
d - Shift Switch

## IDLE STABILIZER SHIFT SYSTEM DESCRIPTION

The idle stabilizer shift system advances ignition timing three degrees each time the outboard is shifted into gear.